

Frame Sprinter

SUITABLE FOR VAN CONVERSIONS



FOR 2 E-BIKES OR 3 STANDARD BICYCLES

New handling for the Carry-Bike series Frame. Composed by a bike carrier and a Kit Frame, which can be purchased separately. For Mercedes Sprinter ≥ 2018 - high roof and super high, allows mounting of the rail support in 3 positions: standard, middle and low*.

FEATURES:

- Stainless steel AISI 304 rail support base
- The geometric configuration of the Carry-Bike allows the rear door of the vehicle to be opened even with the bikes mounted
- Deluxe ladder can be mounted on the left hand door



01 Rail Plus
New design for increased torsion and flexural strength

02 Kit Frame
Stainless steel frame, available in three different models



03 Secure fastening
Using the hinges of the vehicle

04 Stainless steel rail support base
For supporting up to 3 standard bikes or 2 E-Bikes

Kit Frame Crafter



Carry-Bike Frame



Carry-Bike Frame Sprinter

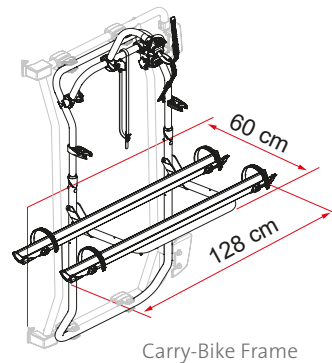

Carry-Bike Frame

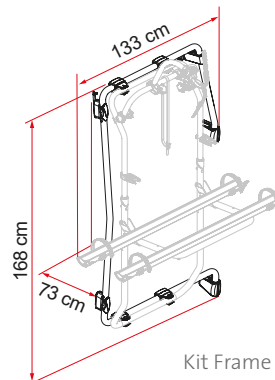

Kit Frame

Description	Carry-Bike Frame	Kit Frame Sprinter
Item No.	02096-35- / 02096-35A	08753-02-
Colour	Aluminium / Deep Black	Stainless steel
Installation		
Vehicle	Van conversion	Van conversion
Technical features		
Bikes carried standard	2	-
Bikes carried max	3	-
Max load	50 kg	-
E-Bike	si	-
Position	rear double door	-
Vertical wheelbase	-	168 cm
Weight	9,4 kg	9,5 kg
Rail type	Rail Premium	-
Bike-Block	Pro S D1 / Pro S D1	-
Distance between rails	23 cm	-
Licence Plate Carrier	●	-

● Standard ○ Optional