

# Frame Ducato

SUITABLE FOR VAN CONVERSIONS



FOR 2 E-BIKES OR 3 STANDARD BICYCLES

New handling for the Carry-Bike series Frame. Composed by a bike carrier and a Kit Frame, which can be purchased separately. For Fiat Ducato, Citroën Jumper, Peugeot Boxer, allows mounting of the rail support in 3 positions: standard, middle and low. Also suitable for vehicles with protruding windows.

## FEATURES:

- Stainless steel AISI 304 rail support base
- The geometric configuration of the Carry-Bike allows the rear door of the vehicle to be opened even with the bikes mounted
- Deluxe ladder can be mounted on the left hand door



**01 Rail Plus**  
New design for increased torsion and flexural strength

**02 Kit Frame**  
Stainless steel frame, available in three different models



**03 Secure fastening**  
Using the hinges of the vehicle

**04 Stainless steel rail support base**  
For supporting up to 3 standard bikes or 2 E-Bikes

Kit Frame Ducato



+

Carry-Bike Frame



=

Carry-Bike Frame Ducato

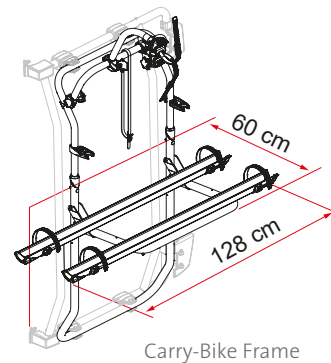

Carry-Bike Frame

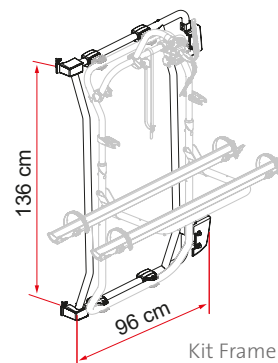

Kit Frame

Description	Carry-Bike Frame	Kit Frame Ducato
Item No.	02096-35- / 02096-35A	08753-01-
Colour	Aluminium / Deep Black	Stainless steel
<b>Installation</b>		
Vehicle	Van conversion	Van conversion
<b>Technical features</b>		
Bikes carried standard	2	-
Bikes carried max	3	-
Max load	50 kg	-
E-Bike	si	-
Position	rear double door	-
Vertical wheelbase	-	136 cm
Weight	9,4 kg	10,8 kg
Rail type	Rail Premium	-
Bike-Block	Pro S D1 / Pro S D1	-
Distance between rails	23 cm	-
Licence Plate Carrier	●	-

● Standard    ● Optional